

Mini-Grids as Valuable Parts of Larger Grids

A proposed scalable mini-grid design concept, forming a new bottom-up approach for establishing power system in remote areas

Per Nørgaard

Center for Electric Power and Energy
Technical University of Denmark
Roskilde, Denmark
pern@elektro.dtu.dk

Tom Cronin

Wind Energy
Technical University of Denmark
Roskilde, Denmark
tochr@dtu.dk

Abstract—The paper presents a design concept and some design principles for the basis of a mini-grid AC power system, being able to start on a small scale, but being prepared to expand with as needs grow, and even being ready to become a valuable part of a larger power system. The concept is based on distributed generation and control, with autonomous active components distributed in the grid, reacting solely on the frequency and the local voltage. The concept may also form the basis for a new bottom-up approach to a fast and feasible way to establish power grids in remote areas. A mini-grid in Kenya is used in the paper to exemplify these principles.

Mini-grid; PV; wind turbines; batteries; distributed control, power system services; optimal reactive power regulation

I. INTRODUCTION

Many populated areas around the World have no access to an electricity grid. Solar + wind + battery based mini-grids are being established in many of these areas. This development is supported by the decreasing costs of the equipment (this goes for PV, wind turbines, batteries, power electronics and the accounting/billing systems) and the development of new business models with digitized and mobile phone-based accounting systems. All of these systems have the potential to expand over time along with the growth of demand, and it may be desirable in the future to connect many of these systems to a larger grid – e.g. connected to neighbouring mini-grids, connected to a larger isolated system, or connected to a national grid. For these systems with a potential to become part of a larger system at a later stage, it is crucial that they are designed to become a valuable part of the larger system, and that the larger systems are designed to benefit from the mini-grids – otherwise some, if not all, of the investments may become

valueless.

II. SOLAR + WIND + BATTERY BASED MINI-GRIDS

In populated areas without access to an electricity grid, people invest in individual solutions for electricity generation – like solar-home systems or small gasoline based generators. The electricity generated in this manner is very expensive, and can only be justified for appliances with little consumption and high value – like lighting and mobile phone charging.

A. Micro grids, mini grids, isolated systems

The nature, design, operation and ownership very much depends on the capacity of the system, and may roughly be divided into three classes: micro-grids, mini-grids and isolated systems (see *Table 1*).

Only AC mini-grids are considered in this paper – either single phase or 3-phase. However, the power system may include a common DC-bus for some of the components (e.g. PV, wind turbine(s) and battery) with a common DC/AC inverter between the DC-bus and the AC grid.

When establishing a mini-grid in such an area, the electricity demand will be very low in the beginning, until the customers have invested in new electric appliances. It therefore makes economic sense for the mini-grid investor to expand the capacity along with the increasing demand. This requires, however, that the system is designed for this.

The basic principle is that power system should be able to deliver the peak power demand at any point in time, as well as the maximum energy demand over a period – typically, a day.

	Micro-grids	Mini-grids	Isolated system
Power level	100 W	10 kW	1 MW
Voltage level	12 Vdc	230 Vac	3×400 Vac
Solution	PV+battery	PV+wind+battery	PV+wind+diesel+battery
Application	Home system	Village grid	Town grid
Ownership	Private	Investor	Local government

Table 1: Typical characteristics of micro-grids, mini-grids and isolated systems.

The cheapest means of providing small-scale electricity generation is, in most cases, by solar power. However, as the demand increases, a combination of solar power and wind power may turn out to be the cheapest way of producing power. As the demand pattern in a PV (+wind) based mini-grid may not follow the generation pattern, batteries are typically introduced to store the excess generation for later use.

It is therefore strongly recommended to start with a small system that is designed to be expanded along with the needs.

The aim of this paper is to present a mini-grid concept and design that is simple, robust, flexible, scalable and able to become a valuable part of a larger power system. This mini-grid system can protect itself against overload and can easily be expanded with the growth in demand by simple “plug-and-play” of more active power components. This requires a simple and robust concept and design of the control and the protection scheme.

B. Batteries

The battery systems are typically one of the more expensive components of mini-grid systems, not just due to the initial capital cost but also because regular maintenance and replacement is necessary. Therefore, the value and cost of the energy provided is very dependent on the battery system. In PV-based micro-systems all the generation is during the day-time, while most of the demands are during night-time. The battery system is thus the only energy source during the night-time. In mini-grids, some of the consumers may be critically dependent on the power supply – for example business applications or health clinics. The battery system should ensure the reliability of the power supply and in isolated systems, distributed battery systems can indeed provide valuable, distributed grid stabilisation support.

Ensuring the high performance of the battery system over its lifetime is highly dependent on the battery management system protecting the battery from being overloaded and balancing the individual cells' state-of-charge (SoC). The power system services, the power performance, the voltage quality and the battery system energy efficiency are, in turn, highly dependent on the DC/AC inverter.

C. Power electronics

Most of the active components in a mini-grid are equipped with power electronics, though which they are connected to the grid system. Power electronics are developing all the time and becoming cheaper, smaller, better (higher voltage, current, power, efficiency and shifting frequency) and more reliable (self-protection). The challenge remains, however, that the power transistors have a maximum operational voltage and current. If the maximum voltage is exceeded, the transistor may be immediately damaged. The maximum current is dependent on the maximum allowable temperature of the semiconductor and, as its inherent thermal capacity is very low, just a short overcurrent may damage the transistor. The lifetime and reliability of power electronics are therefore critically dependent on the design of the built-in self-protection.



Figure 1: Map of Ndeda Island. Source: Google Maps, 2019.

D. Power system services

The critical parameters in a single-phase AC grid are the voltage level, the power level, the waveform and the frequency. In a 3-phase grid, the balance between the three phases is additionally important. The active components in the system can, in different ways and magnitudes, impact these system performance parameters.

The frequency is common for the entire system, and is controlled by the grid forming unit(s) in the system. The frequency may be used to indicate and communicate to the active components, critical balances between generation and consumption at system level, where a high frequency indicates that the system has an excess of power generation available and where a low frequency indicates that the actual consumption is close the maximum system capacity.

The voltage level will vary in the grid in both time and location, depending on the load flow: typically with high voltages close to the generation units and low voltages close to the consumption. Distributed active components (PV units and batteries) can, however, help in stabilising the voltage in the entire grid.

In reality, the active components can only feed or absorb (AC) currents to/from the grid. The phase-shift between the line voltage and the currents to/from the active components defines the ratio between active and reactive power. Reactive power control may at the same time regulate the local voltage and reduce the currents in the power lines.



Figure 2: The solar panels and the wind turbine at Ndeda Island. Photo: Tom Cronin, 2019.

E. The Ndeda system

A 6 kW wind, 9 kW PV, 50 kWh battery based single phase AC mini-grid was established in 2018/19 on the Ndeda Island in Lake Victoria, Kenya. The system is used as an example in this paper. Ndeda is a small island (<2 km long) with only one village and around 5000 citizens, with schools, a health clinic, shops and small business. The predominant business is fishing – see Figure 1 and Figure 2.

III. MINI-GRID CONCEPTS

A. The DC bus concept

The simplest, but least scalable mini-grid concept is to connect all the active components to a common, internal DC bus, connected directly to the battery. The AC grid is provided by a common DC/AC grid forming inverter, connected to the DC bus. New components can easily be connected to the common DC bus.

The most critical design parameter is, however, the voltage level of the DC-bus. The capacity of the system will sooner or later be limited by the voltage level of the DC bus. A power flow of 5 kW at a voltage level of 50 Vdc corresponds to a current of 100 Adc ($P = U \times I$).

It is an obvious design choice to use the terminals of the batteries as the DC bus. However, it may be difficult to connect further batteries in parallel, and therefore difficult to expand the battery capacity.

It is therefore recommended that the design ensures that the voltage level of the DC bus can be increased later on. One way of doing this is by connecting more battery cells in series. All the components connected to the common DC

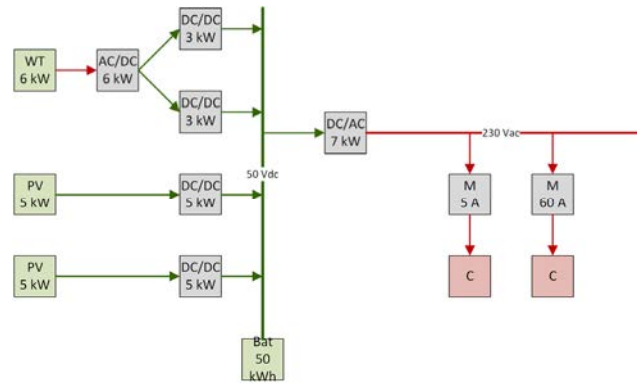

Figure 3: Block diagram of the Ndeda mini-grid power system (WT: wind turbine; PV: solar panels; M: meters; C: customers).

bus must thus be designed to, and prepared for, operating at the higher DC voltage levels. As bidirectional DC/DC converters become cheaper and more efficient, the voltage level of the DC-bus may operate at a different voltage level from that of the battery, offering further flexibility.

In the Ndeda system, both the solar panels and the wind turbine are connected to the battery via individual DC/DC battery charger units, and the AC grid is provided by a single DC/AC inverter, connected to the battery – see Figure 3. The DC/DC battery chargers limit the currents flowing to the battery at a specified maximum, dependent on the battery voltage level. Likewise, the DC/AC inverter limits the current from the battery to a specified minimum battery voltage – all of which protects the battery from being over- or undercharged. In addition, the DC/DC battery chargers provide the ‘maximum power tracking’ function at the input side, controlling and regulating the input voltage for maximum power generation from the solar panels and the wind turbine, respectively.

B. The AC grid based concepts

The more complicated, but more scalable concept, is where the active power components are connected to the AC grid – see Figure 4. This requires that the grid forming unit(s) are sufficiently robust and that all the active components connected at the AC side contribute to stabilising the grid, both in terms of power balancing and voltage regulation. The active power components may be connected to a common AC bus at a central ‘power plant’ or connected somewhere in the AC distribution grid. In the latter case, the distribution grid must be sufficiently strong.

The simplest way to ensure that all the active components contribute to the proper operation of the system is to let them react autonomously based on the frequency and the local voltage. A relatively large variation of the frequency is generally acceptable in mini grid systems, in comparison to national grid systems. The frequency can therefore be used to indicate a system “need” for power regulation. In turn, the local voltage, where the active power component is connected to the grid, can indicate the additional “need” for local voltage regulation. The local voltage level can be regulated by regulation of both the active and reactive power.

This simple control concept requires that all the active power components connected to the grid, as well as the entire power system, are designed for this operation. The

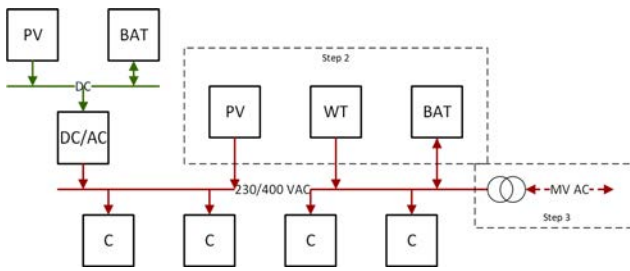

Figure 4: Block diagram of the proposed scalable mini-grid concept with an interconnection to a larger power system (WT: wind turbine; PV: solar panels; BAT: battery; C: customers).

active components must be able to regulate their active and reactive power exchange with the grid, and they should do this on the basis of both the frequency and the local voltage. How, how much and how fast should be individually adjustable.

The impact of the reactive power on the local voltage is dynamic. It is therefore recommended to develop and introduce an autonomous, built-in, ‘optimal reactive power (ORP)’ regulation function in all the active power components. This function could, for example, work in a similar manner to the maximum power point (MPP) tracking function, by constantly regulating the reactive power a little up and down (a slightly randomised pattern is recommended to prevent instability), and then regulate the average reactive power level according to the observed impact on the voltage level.

As all the active power components are expected to be connected to the grid via power electronics, the short circuit current will be low. The grid should therefore be protected by active relays rather than traditional fuses. The protection relays must react both on high current and on low voltage.

The active power components must in addition be able to continue their normal operation after a short grid voltage dip caused by a grid fault. In other words they must have the voltage-ride-through capability.

This autonomous and distributed control concept without a central control makes it simpler to distribute the active components in the grid and to add new active components to the system (plug-and-play). For example, battery systems can be distributed in the grid and not only at the same time contribute to the local and global power balancing but also to the local and global voltage regulations in the grid.

IV. PART OF LARGER SYSTEM

If properly designed, the AC mini-grid concept can, by simple adjustments, be connected to and become a valuable part of a larger power system – either in a cluster of interconnected mini-grids or as part of a larger power system, e.g. a national power system.

A. Mini-grid clusters

Interconnection of a number of mini-grids in a cluster may be relevant for and/or justified by:

- common investments in power generation facilities, typically a wind turbine / farm in a good wind resource location somewhere in between the interconnected mini-grids;

- time-shifted high power loads distributed in the interconnected mini-grids, i.e. high power services (typically productive uses) whose profiles are distributed in time and between the mini-grids, like the different productive uses considered for the Ndeda system: drinking water production, ice production and corn milling;

- increased reliability of the power supply – important for e.g. productive uses and health clinics.

Interconnection of mini-grids will typically be established by 3-phase medium voltage AC power line connections (5-15 kV), depending on the distances and the power requirements. 3-phase AC voltage step up/down transformers are very simple and robust. In the case of a mini-grid based on single phase AC, it will require a 1-phase to 3-phase AC/AC converter.

Most of the high power applications, like electric motors, will require a 3-phase AC connection. So, it may anyhow be necessary to establish a 3-phase AC grid in a mini-grid for supplying high power applications.

It is therefore recommended, from the very beginning, to design a mini-grid system, so it can easily handle 3-phase AC at a later stage. It is specifically recommended to establish the main distribution lines in a mini-grid as 3-phase, 4-wire power lines. The distribution lines to most of the customers can remain single-phase. As long as the system is purely single phase, the wires in the 4-wires power cables can be fully utilised by operating the wires in parallel, two and two.

B. Part of a national system

Mini-grids established in areas that may be connected to a national grid in the future should be designed for this possibility from the start. The national grid must, however, also be designed for realising the benefits of connecting mini-grid systems. The principle is that the mini-grid designers and the national grid designers should agree on the way the power system is controlled, protected and metered, and how the two systems are interconnected. If so, the mini-grids can be a relatively quick and feasible way to provide power grids in remote areas, not yet connected to a national grid, but where the mini-grids can become part of a national power system later on.

This is a bottom-up approach, where a national power system can be established by interconnecting mini-grids that already established in villages, rather than the usual top-down approach, where a national power system is established by expanding a central system. If properly designed, the distributed concept will be more efficient and more reliable than the conventional centralised concept. Parts of the power system may even be able to operate in isolated modes in case of grid faults.

We therefore recommend that, from the beginning, the main distribution lines in the mini-grid are laid out to support a 3-phases power system. We recommend that the protection systems in both power systems are based on active relays. Finally, we recommend that both systems are designed for distributed control of both voltage and power balancing.

V. SUMMARY, CONCLUSIONS AND RECOMMENDATIONS

In this paper, a mini-grid power system is defined as a village power supply system and only AC grids are considered. In a mini-grid, the demand for power will increase over time along with the customers' investments in new appliances and business applications. If the mini-grid is well designed from the very beginning, the mini-grid can be easily expanded to serve the increasing needs, and even becoming a valuable part of a larger power system – a cluster of mini-grids, an isolated power system or a national power system.

Expansion of the system capacity on the AC side is more scalable and flexible than connecting more capacity on the DC side of a common DC/AC grid forming inverter. But the system control becomes more complicated when more active components are connected to the AC grid and thus all these components must be designed to contribute to the proper operation of the power system.

If the system control is based only on the local voltage and the frequency, it is very simple to add new active components, and the active components can even be distributed throughout the grid. This control concept also makes it simple to interconnect more mini-grids and / or connect a mini-grid to a larger power system, where the mini-grid(s) become valuable parts of the larger power system. The active components actual responses to the voltage and frequency may need to be adjusted as the grid develops to ensure stability.

Power systems based on active components connected via power electronics have limited short circuit capacities. The power systems protection schemes should therefore be based on active relays, rather than fuses.

A. Recommendations / proposed design concept

In order to prepare a mini-grid for a simple progression over time from a small system to become part of a larger

power system, we therefore recommend to follow some essential design principles:

- The mini-grid concept and design should be chosen so that it can be easily expanded when needed.
- The system should be designed for expanding its capacity by connecting more active components to the AC grid.
- All active components connected to the AC grid should be able to contribute system services for the proper power system operation, and in addition be able to react autonomously, solely based on the frequency and the local voltage.
- The autonomous active components should be distributed in the grid to minimise the load flow and stabilise the voltages in all parts of the grid.
- The system should initially be a small system, but where the critical parts are already designed for higher loads – e.g. the main power distribution lines.
- If the mini-grid includes DC busses, it is recommended that the DC busses are designed in advance for increasing their power capacities and voltage levels.
- At least part of the mini-grid system and grid should be prepared for 3-phase AC operation. This will enable it to be ready for high power applications and for connecting the mini-grid to a larger grid.

The proposed design concept for mini-grids, following the these recommended design principles, has the potential to form the basis for a new bottom-up approach in establishing national grids in remote areas, not yet connected to a national grid. In this way, the national grid can be established by interconnecting already established mini-grids in the remote villages.